

SITE PLAN

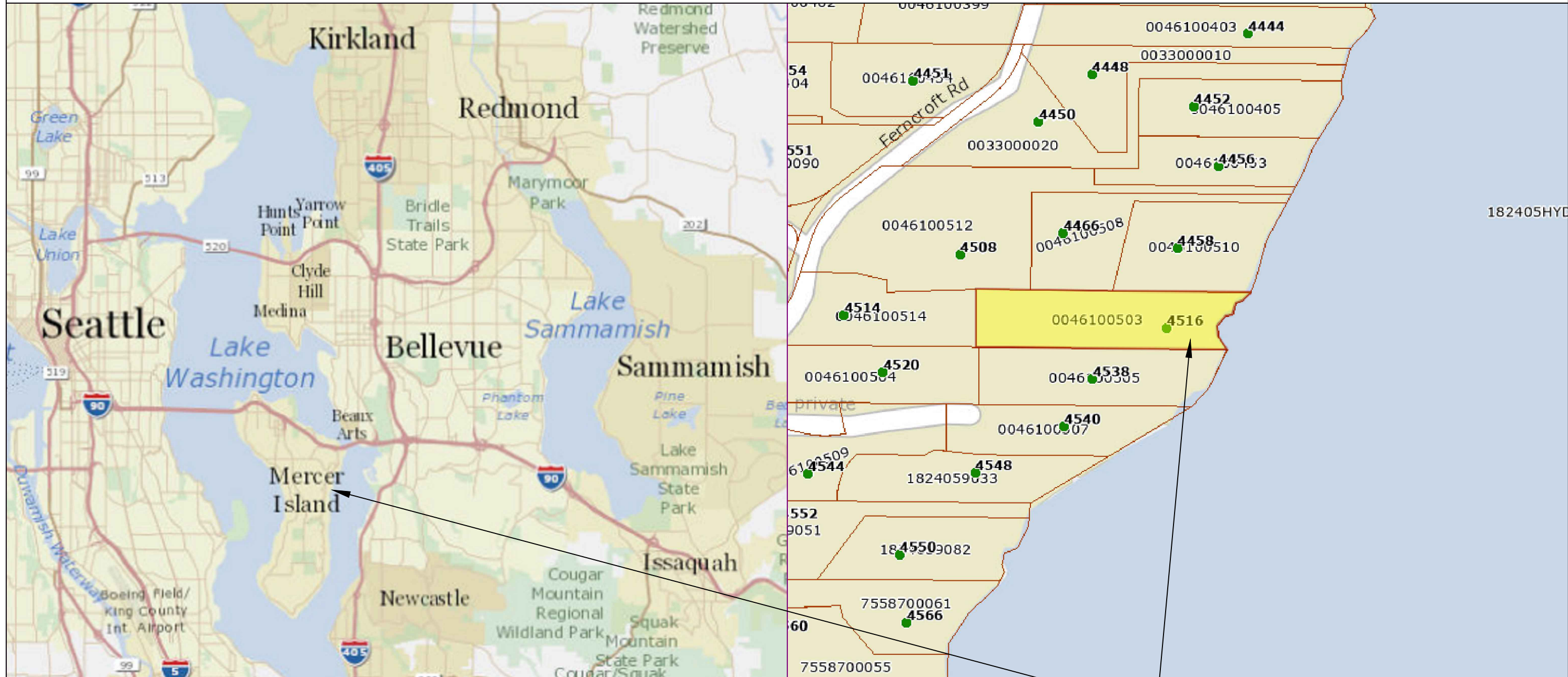

Pin: 004610-0503
 Legal Description: ADAMS LAKE WASHINGTON TRS N 70 FT OF S 200 FT BTWN C/L OF PRIVATE RD & SH OF LAKE WN & SH LDS ADJ LESS POR LY W OF LN BEARING N 00-43-30 W FR PT ON S LN THOF N 89-16-30 E 293.08 FT FR SD PRIVATE RD C/L

Plat Block:
 Plat Lot: 6

Parcel Lat: 47.564938 Long: -122.20853
 Dock Lat: 47.564996 Long: -122.208188

SUBJECT PROPERTY

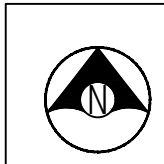

Seaborn Pile Driving
 1080 W Ewing St
 Seattle, WA 98119

Office: 206-236-1700 ext. 3
www.seabornpiledriving.com

Scope of Work: We propose to repair (14) wood piles and (2) wooden mooring piles, remove the existing boathouse, repair the existing dock with new grated decking, remove the existing wooden decking and boat ramp, install gravel to replace the decking over land, and install spawning gravel to replace the boat ramp in-water.

County: King County
 Location: Lake Washington
 Applicant: Cella Residence
 4516 Ferncroft Rd
 Mercer Island, WA 98040
 Datum: CORPS OF ENGINEERS 1919
 SE Quarter Of Section 18, Township 24, Range 05
 Adjacent Owners:
 JIANG RESIDENCE
 4458 FERNCKROFT RD 98040
 JONES RESIDENCE
 4538 FERNCKROFT RD 98040
 Created:
 Last Updated: 12/30/2025 3:36 PM AndrewTon

SHEET A1.0

GENERAL NOTES:

MATERIALS SPEC LIST:

Decking Material: FRPP - Fiberglass reinforced polypropylene

Light permeable percentage:

- * Surface - 53%

Sewer:

- * All sewer is field verified by probing the lake bed manually during the allowed work windows for the area.

Piles:

- * Repair piles are done as a sleeve method
- * All Pile tops exposed will have a conical cap placed on top

CODE REFERENCES: [MERCER ISLAND](#)

We are applying for the permit to be reviewed under the:

“Development Standards for Replacement, Repair and Maintenance of Overwater Structures, Including Moorage Facilities” per MIMC 19.13050(F)(2).

2. Development Standards for Replacement, Repair and Maintenance of Overwater Structures, Including Moorage Facilities. The maintenance, repair and complete replacement of legally existing overwater structures is permitted; provided, that:

- i. All permit requirements of federal and state agencies are met;
 - ii. The area, width, or length of the structure is not increased, but may be decreased;
 - iii. The height of any structure is not increased, but may be decreased; provided, that the height above the OHWM may be increased as provided in subsection (F)(2)(ix)(b) of this section;
 - iv. The location of any structure is not changed unless the applicant demonstrates to the director’s satisfaction that the proposed change in location results in: (A) a net gain in ecological function, and (B) a higher degree of conformity with the location standards for a new overwater structure;
 - v. Piles shall not be treated with pentachlorophenol, creosote, CCA or comparably toxic compounds. If ammoniacal copper zinc arsenate (ACZA) pilings are proposed, the applicant shall meet all of the best management practices, including a post-treatment procedure, as outlined in the amended Best Management Practices of the Western Wood Preservers. All piling sizes are in nominal diameter; Any paint, stain or preservative applied to components of the overwater structure must be leach resistant, completely dried or cured prior to installation. Materials shall not be treated with pentochlorophenol, creosote, CCA or comparably toxic compounds;
 - vii. The applicant shall abide by the work windows for listed species established by the U.S. Army Corps of Engineers and Washington Fish and Wildlife;
 - viii. Disturbance of bank vegetation shall be limited to the minimum amount necessary to accomplish the project. Disturbed bank vegetation shall be replaced with native, locally adapted herbaceous and/or woody vegetation. Herbaceous plantings shall occur within 48 hours of the completion of construction. Woody vegetation components shall be planted in the fall or early winter, whichever occurs first. The applicant shall take appropriate measures to ensure revegetation success; Ch. 19.13 Shoreline Master Program | Mercer Island City Code Page 29 of 34 The Mercer Island City Code is current through Ordinance 20C-13, passed June 16, 2020.
 - ix. Structural Repair. The structural repair, which may include replacement of framing elements, of moorage facilities that results in the repair of more than 50 percent of the structure’s framing elements within a five-year period shall comply with subsections (F)(2)(ix)(a) through (F)(2)(ix)(c) of this section. For this section, framing elements include, but are not limited to, stringers, piles, pile caps, and attachment brackets, as shown in Figure D:
 - a. One hundred percent of the decking area of the pier, dock, and any platform lifts must be fully grated with materials that allow a minimum of 40 percent light transmittance;
 - b. The height above the OHWM for moorage facilities, except floats, shall be a minimum of one and one-half feet and a maximum of five feet; and
 - c. An existing moorage facility that is five feet wide or more within 30 feet waterward from the OHWM shall be replaced or repaired with a moorage face
- Last permit issued for property: 2310-157
Dock established/constructed:



Seaborn Pile Driving
1080 W Ewing St
Seattle, WA 98119

Office: 206-236-1700 ext. 3
www.seabornpiledriving.com

Scope of Work: We propose to repair (14) wood piles and (2) wooden mooring piles, remove the existing boathouse, repair the existing dock with new grated decking, remove the existing wooden decking and boat ramp, install gravel to replace the decking over land, and install spawning gravel to replace the boat ramp in-water.

County: King County
Location: Lake Washington

Applicant: Cella Residence
4516 Ferncroft Rd
Mercer Island, WA 98040

Datum: CORPS OF ENGINEERS 1919
SE Quarter Of Section 18, Township 24, Range 05

Adjacent Owners:
JIANG RESIDENCE
4458 FERNCROFT RD 98040

JONES RESIDENCE
4538 FERNCROFT RD 98040

Created:

Last Updated: 12/30/2025 3:36 PM AndrewTon

**SHEET
A2.0**

EXISTING CONDITIONS

****CLEAN UP LAKE AROUND PROJECT****

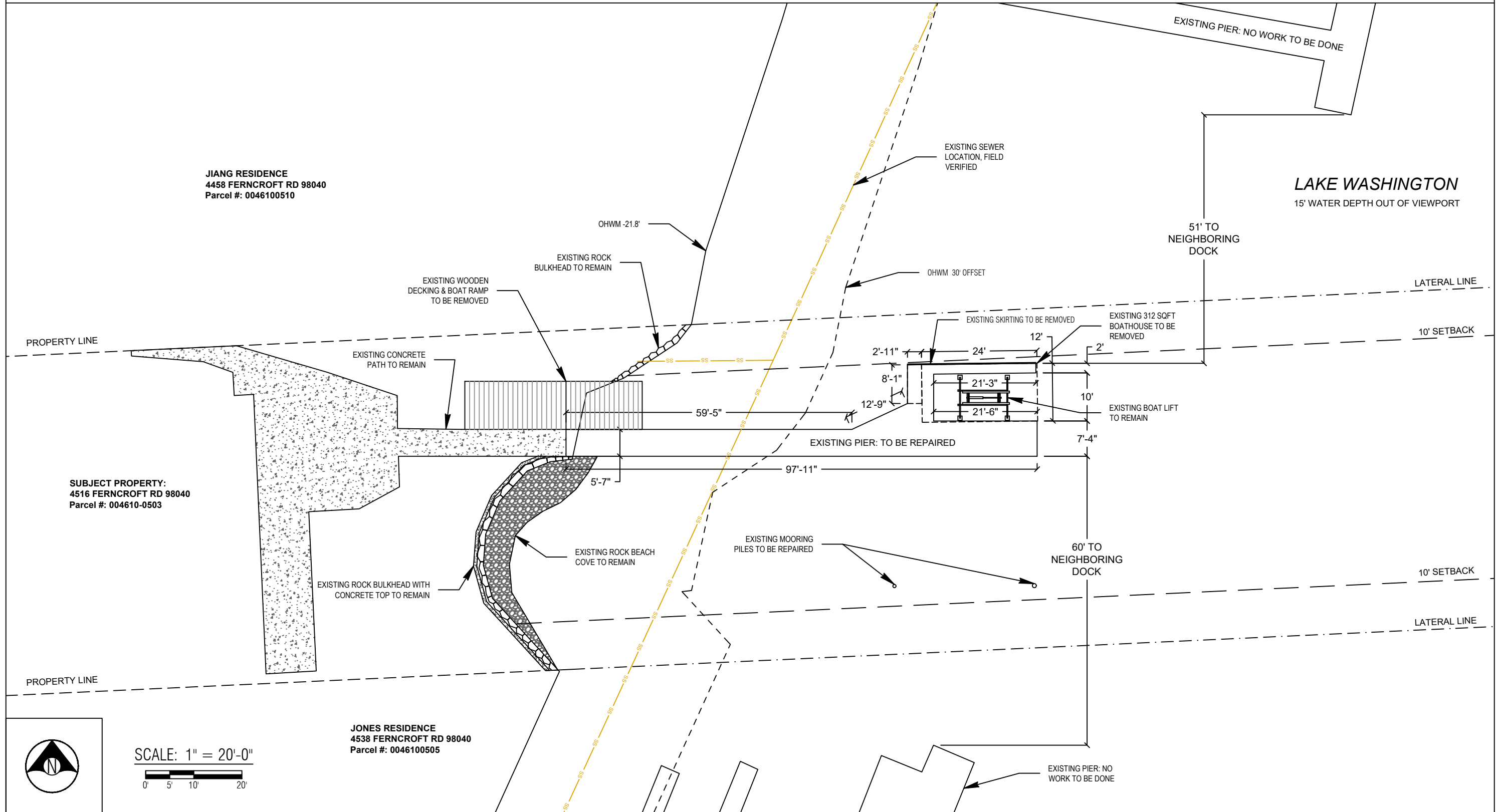

County: King County
 Location: Lake Washington
 Applicant: Cella Residence
 4516 Ferncroft Rd
 Mercer Island, WA 98040
 Datum: CORPS OF ENGINEERS 1919
 SE Quarter Of Section 18, Township 24, Range 05
 Adjacent Owners:
 JIANG RESIDENCE
 4458 FERNCROFT RD 98040
 JONES RESIDENCE
 4538 FERNCROFT RD 98040
 Last Updated: 12/30/2025 3:36 PM AndrewTon
 Created:

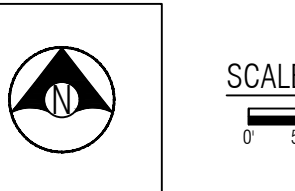

Seaborn Pile Driving
 1080 W Ewing St
 Seattle, WA 98119
 Office: 206-236-1700 ext. 3
 www.seabornpiledriving.com

Scope of Work: We propose to repair (14) wood piles and (2) wooden mooring piles, remove the existing boathouse, repair the existing dock with new grated decking, remove the existing wooden decking and boat ramp, install gravel to replace the decking over land, and install spawning gravel to replace the boat ramp in-water.

SHEET A3.0
 NWS-2021-XXX
 PAGE 3 OF 8

PROPOSED CONDITIONS

****CLEAN UP LAKE AROUND PROJECT****

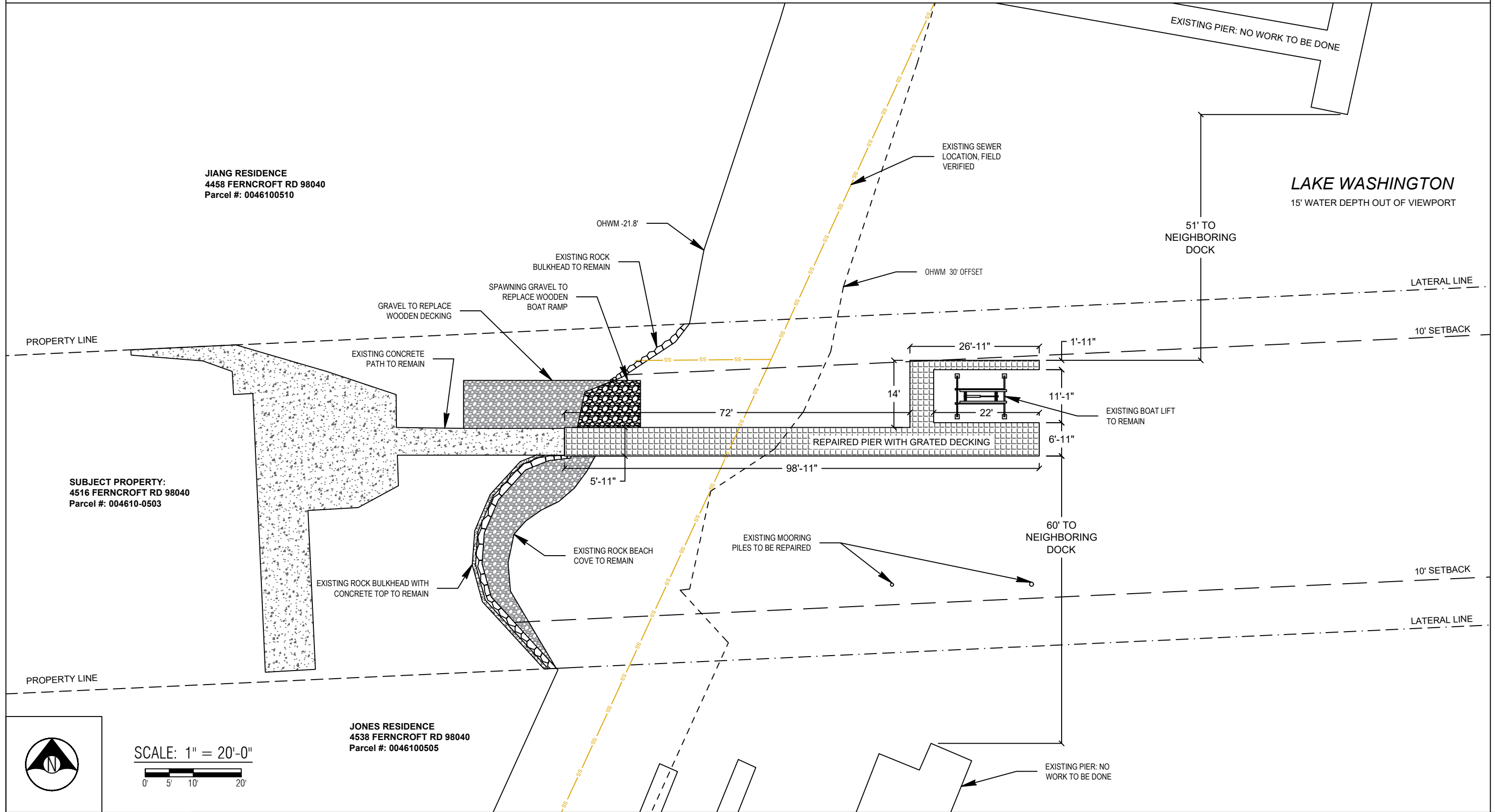

County: King County
Location: Lake Washington

Applicant: Cella Residence
4516 Ferncroft Rd
Mercer Island, WA 98040

Datum: CORPS OF ENGINEERS 1919
SE Quarter Of Section 18, Township 24, Range 05

Adjacent Owners:
JIANG RESIDENCE
4458 FERNCROFT RD 98040

JONES RESIDENCE
4538 FERNCROFT RD 98040

Created: Last Updated: 12/30/2025 3:36 PM AndrewTon



Seaborn Pile Driving
1080 W Ewing St
Seattle, WA 98119

Office: 206-236-1700 ext. 3
www.seabornpiledriving.com

Scope of Work: We propose to repair (14) wood piles and (2) wooden mooring piles, remove the existing boathouse, repair the existing dock with new grated decking, remove the existing wooden decking and boat ramp, install gravel to replace the decking over land, and install spawning gravel to replace the boat ramp in-water.

SHEET A4.0

NWS-2021-XXX
PAGE 4 OF 8

PIER DETAILS - EXISTING/PROPOSED

LEGEND

- (14) EXISTING PILES - TO BE REPAIRED
- (2) EXISTING MOORING PILES - TO BE REPAIRED
- (9) EXISTING PILES - NO WORK TO BE DONE

Existing Pier Overwater: 720 sqft

New Pier Overwater: 710 sqft

- Gravel to be Installed Overland: 4.7cy
- Spawning Gravel to Replace Boat Ramp: 2cy

--- 312 sqft Boat House to be Removed

**Grated decking is 53% light permeable

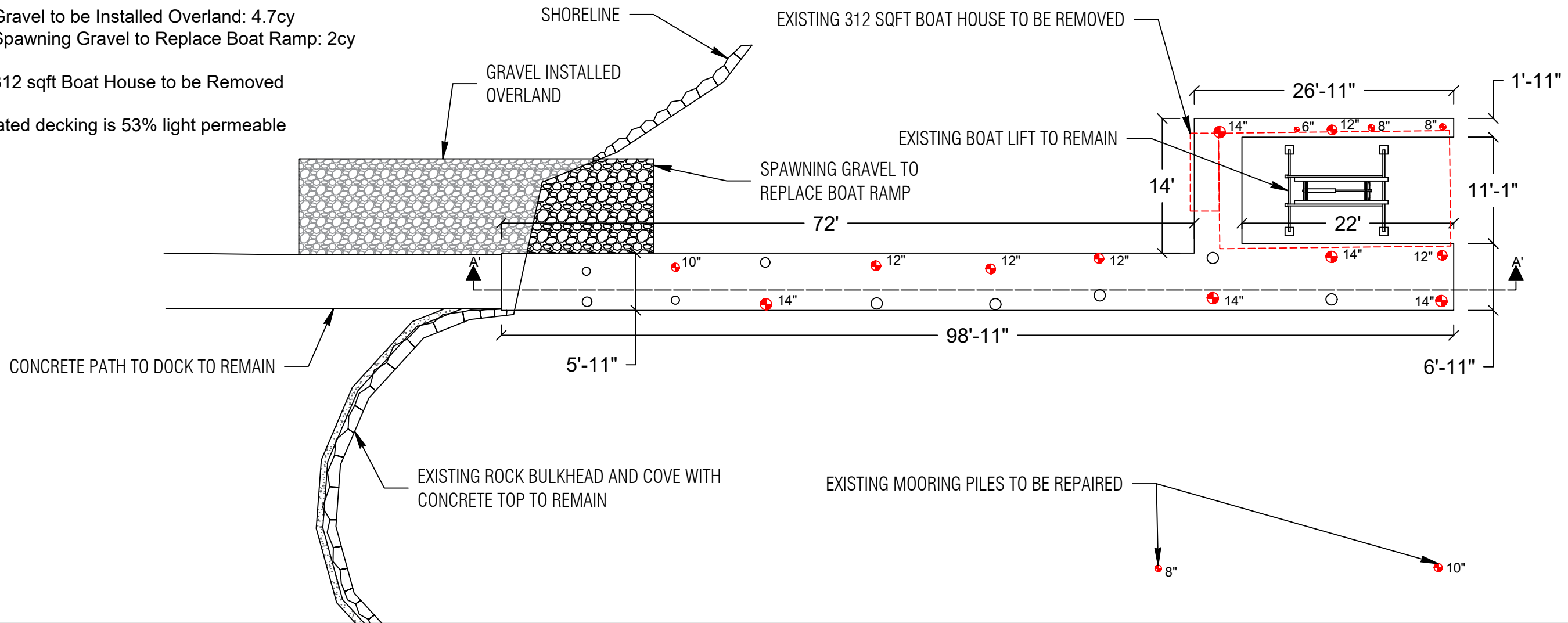

PLAN VIEW



Seaborn Pile Driving
1080 W Ewing St
Seattle, WA 98119

Office: 206-236-1700 ext. 3
www.seabornpiledriving.com

Scope of Work: We propose to repair (14) wood piles and (2) wooden mooring piles, remove the existing boathouse, repair the existing dock with new grated decking, remove the existing wooden decking and boat ramp, install gravel to replace the decking over land, and install spawning gravel to replace the boat ramp in-water.

County: King County
Location: Lake Washington

Applicant: Cella Residence
4516 Ferncroft Rd
Mercer Island, WA 98040

Datum: CORPS OF ENGINEERS 1919
SE Quarter Of Section 18, Township 24, Range 05

Adjacent Owners:
JIANG RESIDENCE
4458 FERNCROFT RD 98040

Last Updated: 12/30/2025 3:36 PM AndrewTon

Created:

**SHEET
A5.0**

NWS-2021-XXX
PAGE 5 OF 8

PIER DETAILS EXISTING/PROPOSED

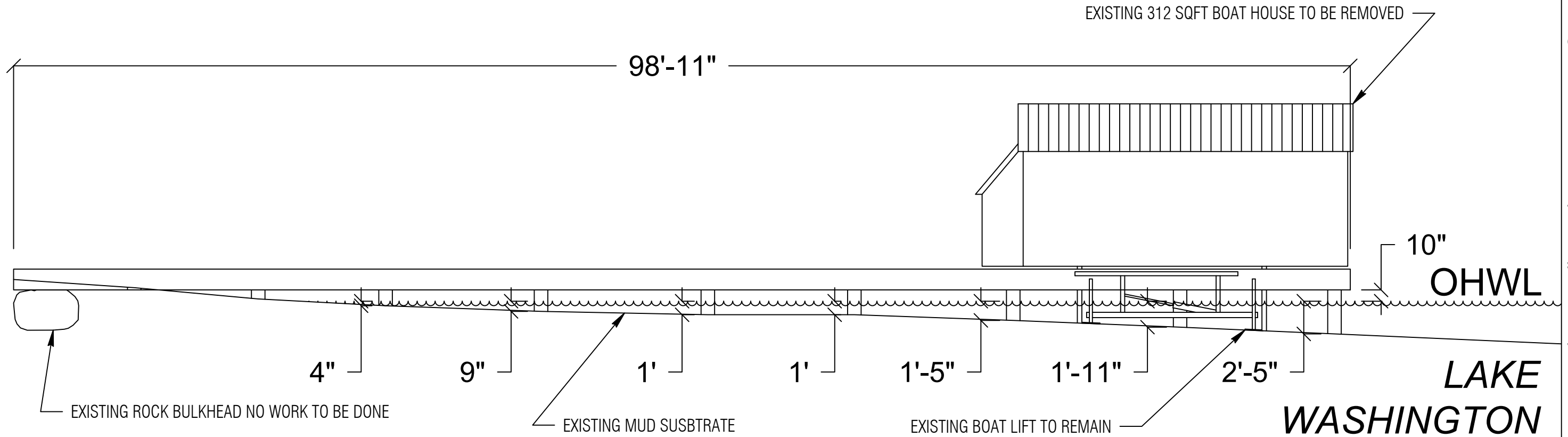

SECTION VIEW: A'-A'



Seaborn Pile Driving
1080 W Ewing St
Seattle, WA 98119

Office: 206-236-1700 ext. 3
www.seabornpiledriving.com

Scope of Work: We propose to repair (14) wood piles and (2) wooden mooring piles, remove the existing boathouse, repair the existing dock with new grated decking, remove the existing wooden decking and boat ramp, install gravel to replace the decking over land, and install spawning gravel to replace the boat ramp in-water.

County: King County
Location: Lake Washington

Applicant: Cella Residence
4516 Ferncroft Rd
Mercer Island, WA 98040

Datum: CORPS OF ENGINEERS 1919
SE Quarter Of Section 18, Township 24, Range 05

Adjacent Owners:
JIANG RESIDENCE
4458 FERNCROFT RD 98040

JONES RESIDENCE
4538 FERNCROFT RD 98040

**SHEET
A6.0**

NWS-2021-XXX
PAGE 6 OF 8

Created:

Last Updated: 12/30/2025 3:36 PM AndrewTon

BMP INFORMATION

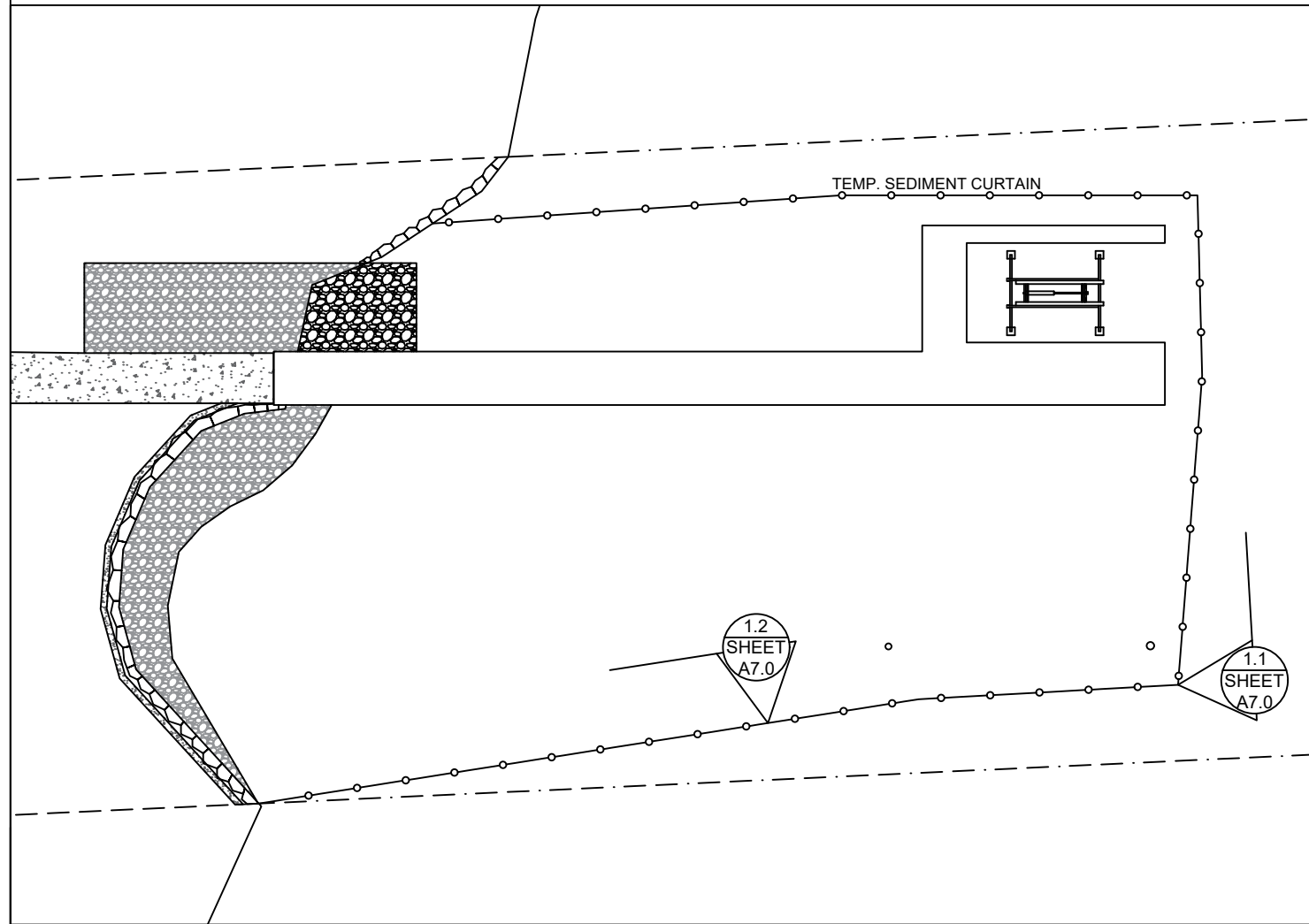

BMP NOTES:

- A. Constant vigilance shall be kept for the presence of protected fish species during all aspects of the proposed action, particularly during in-water activities such as vessel movement, deployment of anchors & spuds, pile driving, dredging, and placement of gravels and other fill.
1. The project manager shall designate an appropriate number of competent observers to survey the project site and adjacent areas for protected species, including the presence of fish as conditions allow.
 2. Visual surveys shall be made prior to the start of work each day, and prior to resumption of work following any break of more than an hour. Periodic additional visual surveys throughout the work day are strongly recommended.
 3. All in-water work shall be done during the in-water work window for the waterbody. Where there is a difference between the USCOE and WDFW work windows, the overlap of the two shall apply.
 4. All pile driving and extraction shall be postponed or halted when obvious aggregations or schooling of fish are observed within 50 yards of that work, and shall only begin/resume after the animals have voluntarily departed the area.
 5. When piloting vessels, vessel operators shall operate at speeds and power settings to avoid grounding vessels, and minimize substrate scour and mobilization of bottom sediments.
- B. No contamination of the marine environment shall result from project-related activities.
1. Appropriate materials to contain and clean potential spills shall be stored and readily available at the work site and/or aboard project-related vessels.
 2. The project manager and heavy equipment operators shall perform daily pre-work equipment inspections for cleanliness and leaks. All heavy equipment operations shall be postponed or halted should a leak be detected, and shall not proceed until the leak is repaired and the equipment is cleaned.
 3. To the greatest extent practicable, utilize biodegradable oils for equipment that would be operated in or near water.
 4. Fueling of land-based vehicles and equipment shall take place at least 50 feet away from the water, preferably over an impervious surface. Fueling of vessels shall be done at approved fueling facilities.
 5. Turbidity and siltation from project-related work shall be minimized and contained through the appropriate use of erosion control practices, effective silt containment devices, and the curtailment of work during adverse weather and tidal/flow conditions.
 6. All wastes shall be collected and contained for proper disposal at approved upland disposal sites appropriate for the material(s).
 7. When removing piles and other similarly treated wood, containment booms must fully enclose the work area. Wood debris, oils, and any other materials released into lake waters must be collected, removed, and properly disposed of at approved disposal sites.
 8. All in- and over-water wood cutting would be limited to the minimum required to remove the subject wood component, and all cutting work should be enclosed within floating containment booms.
 9. When removing piles, no actions shall be taken that would cause adhering sediments to return to lake waters.
 10. Above-water containment shall be installed around removed piles to prevent sediment laden waters from returning to lake waters.
 11. Construction staging (including stocking of materials, etc.) will occur on the supply barge.
 12. All Exposed wood to be used on the project will be treated with a cheminite treatment.

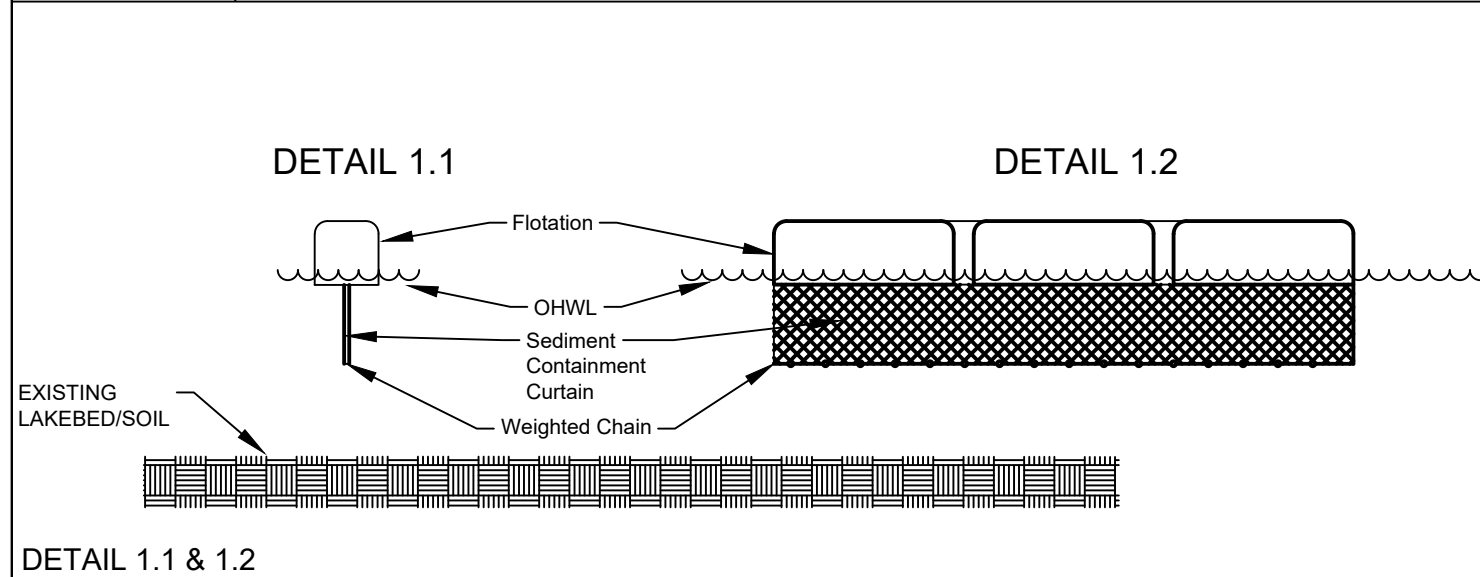

DETAIL 1.1 & 1.2



Seaborn Pile Driving
1080 W Ewing St
Seattle, WA 98119

Office: 206-236-1700 ext. 3
www.seabornpiledriving.com

Scope of Work: We propose to repair (14) wood piles and (2) wooden mooring piles, remove the existing boathouse, repair the existing dock with new grated decking, remove the existing wooden decking and boat ramp, install gravel to replace the decking over land, and install spawning gravel to replace the boat ramp in-water.

Datum: CORPS OF ENGINEERS 1919
SE Quarter Of Section 18, Township 24, Range 05

County: King County
Location: Lake Washington

Applicant: Cella Residence
4516 Ferncroft Rd
Mercer Island, WA 98040

Adjacent Owners:
JIANG RESIDENCE
4458 FERNCKROFT RD 98040

JONES RESIDENCE
4538 FERNCKROFT RD 98040

Created: Last Updated: 12/30/2025 3:36 PM AndrewTon

**SHEET
A7.0**

MITIGATION PLAN

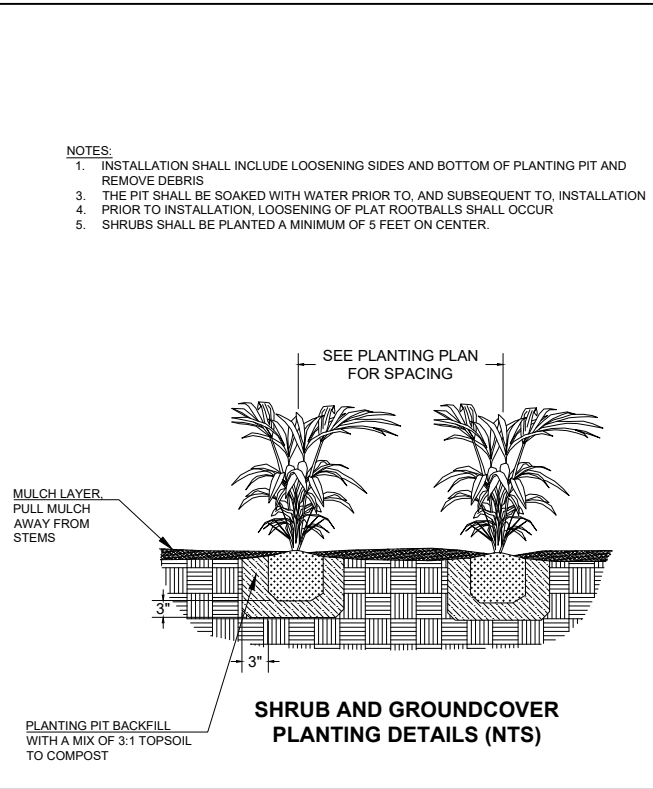
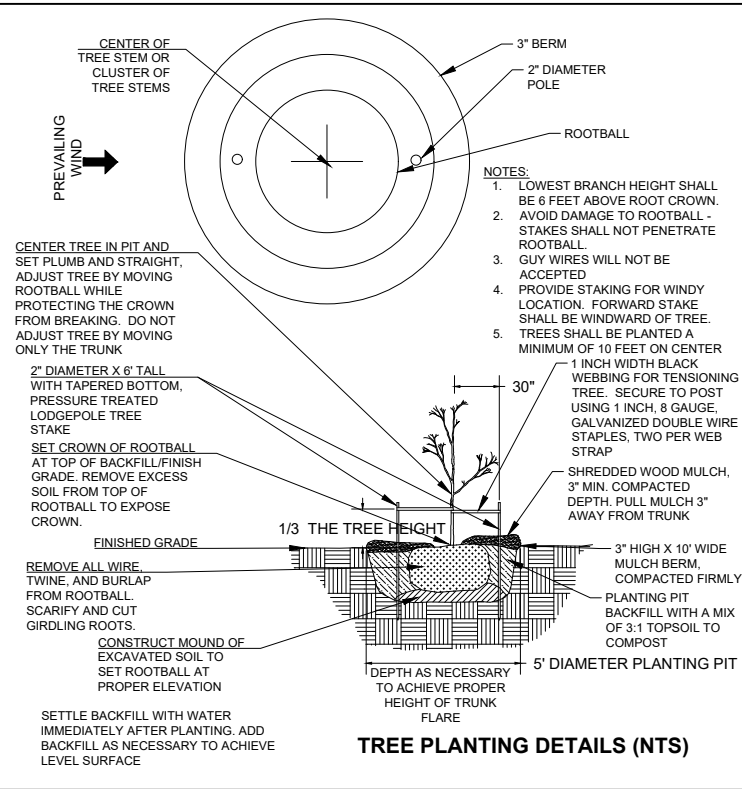
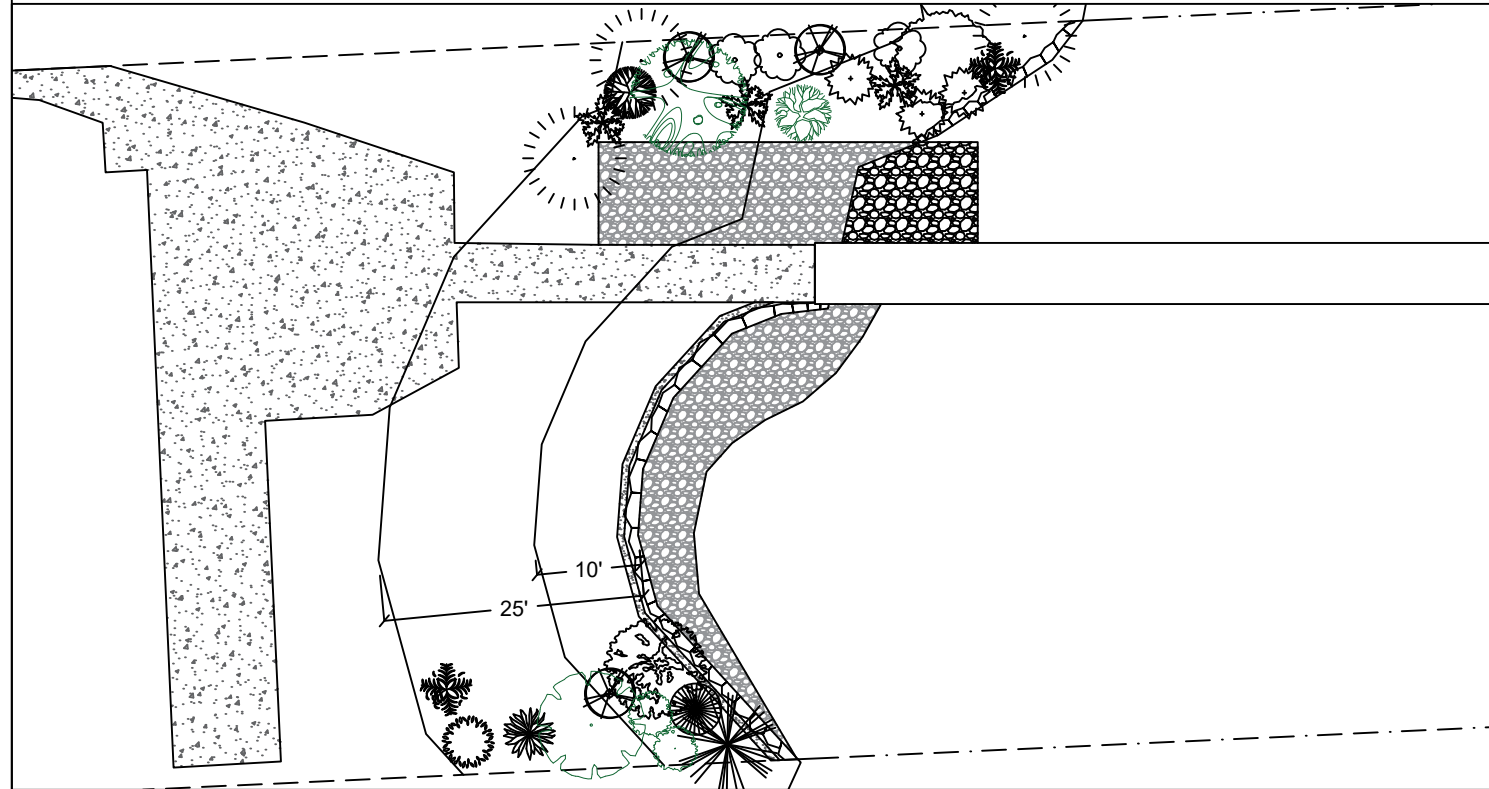

Notes:

1. Shrubs are show, and shall be planted, at least five feet on center. Trees are show, and shall be planted, at least ten feet to center.
2. The property owner will implement and abide by the shoreline planting plan. The plants shall be installed before or concurrent with the work authorized by this permit. A report, as-built drawing and photographs demonstrating the plants have been installed or a report on the status of project construction will be submitted to the U.S. Army Corps of Engineers, Seattle District, Regulatory Branch, within 12 months from the date of permit issuance. This reporting requirement may be met by completing and submitting a U.S. Army Corps of Engineers approved Report for Mitigation Work Completion form.
3. The property owner will maintain and monitor the survival of installed shoreline plantings for five years after the U.S. Army Corps of Engineers accepts the as-built report. Installed plants shall achieve 100% survival during monitoring Years 1 and 2. Installed plants shall achieve at least 80% survival during monitoring Years 3, 4 and 5. Percent survival is based on the total number of plants installed in accordance with the approved riparian planting plan. Individual plants that die will be replaced with native riparian species in order to meet the survival performance standards.
4. The property owner will provide annual monitoring reports for five years (Monitoring Years 1-5). Each annual monitoring report will include written and photographic documentation on plant mortality and replanting efforts and will document whether the performance standards are being met. Photos will be taken from established points and used repeatedly for each monitoring year. In addition to photos at designated points, photo documentation will include a panoramic view of the entire planting area. Submitted photos will be formatted on standard 8 1/2 x 11" paper, dated with the date the photo was taken, and clearly labeled with the direction from which the photo was taken. The photo location points will be identified on an appropriate drawing. Annual shoreline planting monitoring reports will be submitted to the U.S. Army Corps of Engineers, Seattle District, Regulatory Branch, by November 31 of each monitoring year. This reporting requirement may be met by completing and submitting a U.S. Army Corps of Engineers approved Mitigation Planting Monitoring Report form.

PROPOSED PLANTING SPECIES/QUANTITIES

SYMBOL	LATIN NAME	COMMON NAME	QTY	SIZE
	Thuja plicata	Western Red Cedar	1	3 ft
	Pinus contorta v contorta	Shore pine	1	3 ft
	Rosa nutkana	Nootka Rose	1	1 Gallon
	Philadelphus lewisii	Mock Orange	2	1 Gallon

PLANTS: Shrubs to be installed 5ft on center and trees to be installed 10ft on center.

Applicant will be paying into the King County Mitigation Fund the remaining amount as depicted in the RAP Calculator



Seaborn Pile Driving
1080 W Ewing St
Seattle, WA 98119

Office: 206-236-1700 ext. 3
www.seabornpiledriving.com

Scope of Work: We propose to repair (14) wood piles and (2) wooden mooring piles, remove the existing boathouse, repair the existing dock with new grated decking, remove the existing wooden decking and boat ramp, install gravel to replace the decking over land, and install spawning gravel to replace the boat ramp in-water.

County: King County
Location: Lake Washington

Applicant: Cella Residence
4516 Ferncroft Rd
Mercer Island, WA 98040

Datum: CORPS OF ENGINEERS 1919
SE Quarter Of Section 18, Township 24, Range 05

Adjacent Owners:
JIANG RESIDENCE
4458 FERNCROFT RD 98040

Created: JONES RESIDENCE
4538 FERNCROFT RD 98040

Last Updated: 12/30/2025 3:36 PM AndrewTon

SHEET A8.0

NWS-2021-XXX
PAGE 8 OF 8